

Characteristics

Principle of Operation

Faraday isolators are optical components which allow light travel in only one direction. Their mode of operation is based on the Faraday effect (linear magneto-optical effect). In principle, the function of an optical isolator is analogue to that of an electrical diode.

Faraday isolators are composed of three elements:

- Entrance Polarizer
- Faraday Rotator
- Exit Polarizer

Thin film polarizers are commonly used as entrance and exit polarizers, typically in form of a special polarizing beam splitter cube. These polarizers have an extremely high extinction ratio and are designed for use with high power lasers. The polarizer entrance and exit surfaces are coated with an antireflective coating for the specified wavelength range. The key element of the Faraday isolator is the Faraday rotator. The rotator consists of a strong permanent magnet containing a crystal with a high Verdet constant.

Light of any polarization entering the entrance polarizer exits it as horizontally or vertically linearly polarized light. Since laser light is usually linearly polarized, one can match the orientation of the entrance polarizer and the polarization of the laser by simply rotating the isolator. Light then passes through the Faraday rotator. For most wavelengths the crystal is a Terbium Gallium Garnet (TGG) crystal which is placed in a strong homogeneous magnetic field. Crystal length and magnetic field strength are adjusted so that the light polarization is rotated by 45° on exiting the crystal. In the figure above, the light is rotated counter clockwise when viewed in the

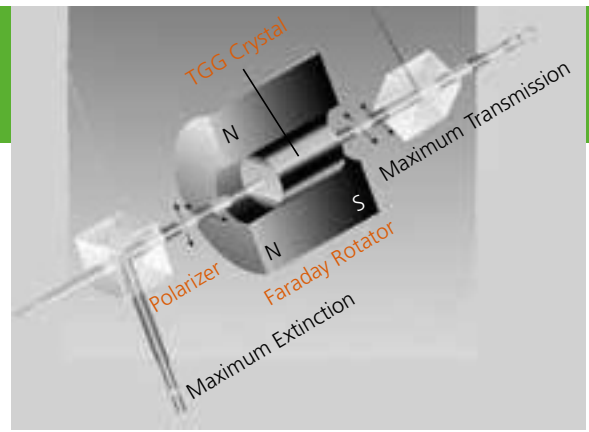

north/south direction of the magnetic field ($\pm 45^\circ$) and the exit polarizer is also oriented at $\pm 45^\circ$, so that the maximum beam intensity is transmitted.

If light of any polarization, but with a reversed direction of propagation, meets the exit polarizer, it leaves at $\pm 45^\circ$, passes through the Faraday rotator and is again rotated by $\pm 45^\circ$. The non-reciprocal nature of the Faraday effect results in the direction of rotation once again being counter clockwise as viewed in the north/south direction of the magnetic field. Upon leaving the Faraday rotator, the polarization has gone through two $\pm 45^\circ$ rotations resulting in a total rotation of $\pm 90^\circ$. In this polarization direction the light is deflected laterally by the entrance polarizer.

Increased Isolation

The maximum isolation of the Faraday isolator is limited by inhomogeneities of the TGG crystal and the magnetic field. However, it is possible to square the extinction ratio by placing two isolators in series and by arranging the polarity of the two magnets to be opposite to each other. This way the polarization direction of the transmitted light remains unchanged in the transmission direction and the effect of both magnetic fields is enhanced. This arrangement also leads to a more compact isolator. The strength of this effect depends on the distance between the two magnets and can be used to tune the isolator to different wavelengths. The adjustment is necessary because the rotational angle of the TGG crystal is wavelength and temperature dependent. Please see section "Two Stage Isolators" (page 20) for more information.

Advantages

High Isolation

The properties of the LINOS Faraday isolators are determined by the quality of the optical elements and the uniformity of the magnetic field. The entrance and exit polarizers exhibit a very high extinction ratio, so that the isolation is mainly limited by inhomogeneities in the crystal material. Specially selected crystal materials with a high Verdet constant combined with permanent magnets with a high remanence enable Qioptiq to use shorter crystals and obtain an isolation > 30 dB.

The radiation blocked by the entrance and exit polarizers is not absorbed internally, but is deflected by 90° with respect to the beam direction. This ensures a stable thermal operation even at higher laser power levels. The blocked radiation can be used for other applications. All optical surfaces are slightly tilted relative to the beam axis.

Low Insertion Loss

The high transmission, typically > 90%, is achieved by using materials with low absorption and anti-reflective coatings with low residual reflectivity on all entrance and exit surfaces.

Large Aperture, Compact Design

All optical elements have been aligned to eliminate beam shading and allow for easy adjustment. Focusing is not necessary. The compact design is achieved by using rare earth magnets with the highest remanent magnetism and TGG crystal material with a high Verdet constant. The isolator is suitable for divergent beams or in setups with limited space. A minimal optical path length in the isolator results in the lowest possible influence on the image.

Three sides of the entrance and exit polarizers are usable and readily accessible for easy cleaning. The degree of isolation can be adjusted over a wide range.

Mounting Flexibility

The LINOS Faraday isolators can be mounted directly via threaded holes in the housing or via additional base plates or angle brackets. New rotatable Faraday isolators are available.

Applications

The ongoing development and refinement of laser technology have created a need for optical components that shield the laser resonator from back reflections. LINOS Faraday isolators provide an efficient method of suppressing instabilities and intensity fluctuations in laser devices.

Typical Applications are:

- Protection of the resonator in solid state and gas lasers from back reflections
- Prevention of parasitic oscillation in multistage solid state amplifiers
- Protection of diode lasers against back scatter and extraneous light

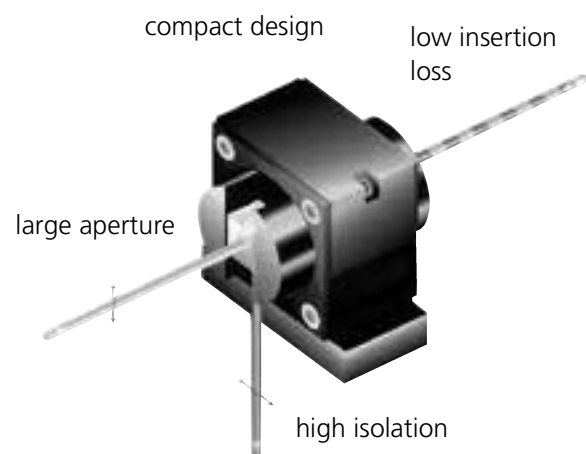

Isolators with a Broad Tuning Range

Technical Overview

The function of the tunable LINOS Faraday isolators in the following section is based on a single stage isolator. Precision mechanics allow a continuous adjustment of the interaction between the magnetic field and the TGG crystal without moving any optical components.

It is possible to set the rotation angle to any value between 0° to 45° within the wavelength range in order to study the effects of varying degrees of feedback. Easy access to the blocked beam is provided by polarizing beam splitter cubes, which divert the blocked beam by 90° .

Precision mechanics allow the exact reproduction of adjustments previously established. With the addition of an optional micrometer display, an angular resolution in the arc minute range is achievable. The incorporation of very powerful magnets ensures a compact and efficient design.

Operation

The isolator can be mounted on rods, cylindrical mounts or by using the assembly surfaces so that the laser polarization can be oriented horizontally or vertically. The entry and exit polarizers can be easily cleaned by removing the security rings.



Applications

These isolators are suitable for all lasers operating in the ranges 430-460 nm and 500-1100 nm wavelength range especially for:

- Ar+ and Kr+ lasers
- Other Ion lasers
- HeNe lasers
- Other gas lasers
- Diode lasers
- Nd:YAG lasers
- Ti: Sapphire lasers
- Cr:LiCAF lasers
- Dye lasers
- Alexandrite lasers
- Mode-locked lasers
- Short-pulse lasers
- Tunable lasers

Tunable Isolators with 5 mm Aperture, SV/SI Series



FI-x/y-5SV / FI-x/y-5SI

- Continuous adjustment for wavelength without movement of optical components
 - Tunable with maximum transmission and isolation over the complete wavelength range
 - Isolation better than 30 dB, typically 38-42 dB over the entire wavelength range
 - Custom isolation values on request
 - TGG crystal
 - Access to blocked beam
- Mounting: via two M4 threaded holes on the bottom side and the back side, 20 mm separation (5SV-version), 55 mm separation (5SI-version), or via base plate, or via angle bracket (5SV-version only)
 - Base plate included, angle bracket included (5SV-version only)

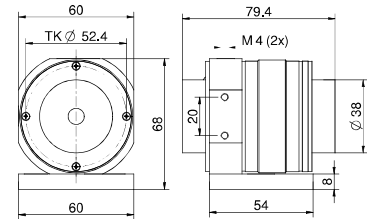

FI-x/y-5SV

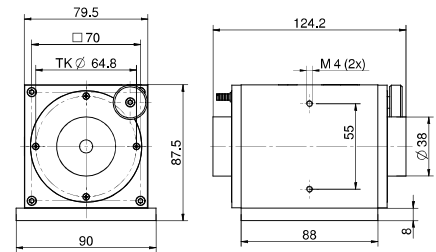

FI-600/1100-5SI



18

Tunable Isolators with 5 mm aperture, SV/SI Series

Product	Isolation, guaranteed/typical (dB)	Transmission at design wavelength (%)	Tuning range typical (nm)	Aperture Ø (mm)	Dimensions (mm)	Dimensions base pate (LxWxH) (mm)	Damage threshold @ 1.2 ps pulses (J/cm ²)	Damage threshold @ 8 ns pulses (J/cm ²)	Part No.
FI-430/460-5SV	> 30/38-42	> 90	430 - 460	5	60x60x79.4	54x60x8	0.1 @ 460 nm	3.7 @ 460 nm	84501046001
FI-500/820-5SV	> 30/38-42	> 90	500 - 820	5	60x60x79.4	54x60x8	0.2 @ 820 nm	0.8 @ 820 nm	84501041000
FI-600/1100-5SI	> 30/38-42	> 90	600 - 1100	5	79.5x79.5x124.2	88x90x8	0.2 @ 1060 nm	1.1 @ 1060 nm	84501044000

Subject to technical changes

Tunable Isolator with 8 mm Aperture



- Continuous adjustment for wavelength without movement of optical components
- Tunable with maximum transmission and isolation over the complete wavelength range
- Isolation better than 30 dB, typically 38-42 dB over the entire wavelength range
- Custom isolation values on request
- TGG crystal
- Access to blocked beam
- Mounting: via two M4 threaded holes at the bottom side and the back side, 55 mm separation, or via base plate
- Base plate included

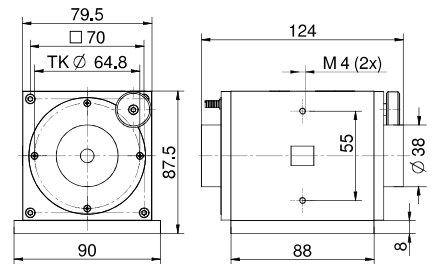

High quality

Precision engineering parts enable smooth continuous wavelength adjustment. Without movement of the optics a broad wavelength range is realized.

Tunable Isolator with 8 mm aperture

Product	Isolation, guaranteed/typical (dB)	Transmission at design wavelength (%)	Tuning range typical (nm)	Aperture Ø (mm)	Dimensions (mm)	Dimensions base plate (LxWxH) (mm)	Damage threshold @ 1.2 ps pulses (J/cm ²)	Damage threshold @ 8 ns pulses (J/cm ²)	Part No.
FI-600/1100-8SI	>30/38-42	>90	600 - 1100	8	79.5x79.5x124	88x90x8	0.2 @ 1060 nm	1.1 @ 1060 nm	84501045000

Subject to technical changes